



## **General information – English**

This general information explains how to use correctly the anchors.

The general information must be associated to the technical data sheet and the user's manual.

Read both documents to have a complete information and ascertain to understand well all the information, before using the product. Only the techniques shown without symbol of death are authorized. Keep up with the updates and of all the additional information on the site [www.lappasclimbing.com](http://www.lappasclimbing.com).

In case of doubt or difficulty to understand the information, don't risk, but contact:

LAPPAS S.A.

5<sup>th</sup> km nat.rd Ioannina-Athens

45500 Ioannina

Greece

Tel : +30 26510 41855

email: [info@lappasclimbing.com](mailto:info@lappasclimbing.com)

[www.lappasclimbing.com](http://www.lappasclimbing.com)

### **Anchor Device:**

**Model: IAPETUS TITAN 10x95mm**

**IAPETUS TITAN 10x115mm**

### **Reference Standards:**

- 1) **Rock anchor - EN 959:2018**  
"Mountaineering equipment – Rock Anchors – Safety requirements and test methods"
- 2) **UIAA 123 (for Rock Anchor Devices)**  
"Mountaineering and Climbing Equipment – Rock Anchors"

**Material: Titanium Gr2**

## **USE AND APPLICATION**

The anchors **IAPETUS TITAN 10x95 | 10x115mm**, are tested according to EN 959:2018 designed for use as rock anchors. Rock anchors are defined as anchor devices insert in a rock hole, held in place by epoxy glue and with an attachment point for a connector. The anchor device is tested according to UIAA 123\_3 - rock anchors.

**WARNING:**

Don't stress the product beyond its limits or in other different situations than that for which it is intended. Check that the product is compatible with the other materials you want to use: contact LAPPAS S.A. if you are not sure of the compatibility.

It is possible to directly connect the rope to the eyelet of the anchor for the items **IAPETUS TITAN 10x95mm | 10x115mm.**

**Attention: activities involving the use of this device are all dangerous and high-risk and may also involve in fatal injuries. Make sure you fully understand the use of this product and work out in how to use it, to familiarize yourself with it and learn to know its performances and limits.**

**NOMENCLATURE**

**A) IAPETUS TITAN 10x95mm | 10x115mm**

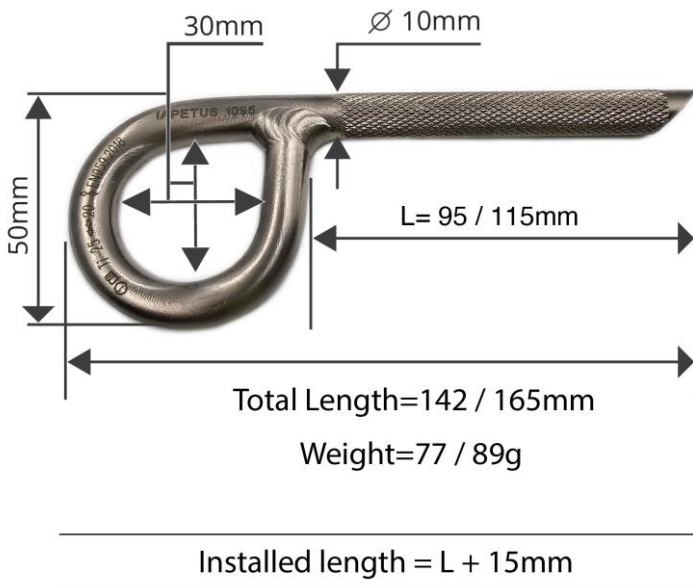

**DYNAMIC STRENGTH TESTS**

- 1) Direction parallel to longitudinal axis of the device
- 2) Direction perpendicular to longitudinal axis of the device

**MARKING**

Producer: Lappas S.A. – identified with logo “Lappas”

Pictogram indicating the need to read the instructions before use



Identification serial number

Serial number (week/year): example 10/2024

- 10= week of year
- 20=2020 year

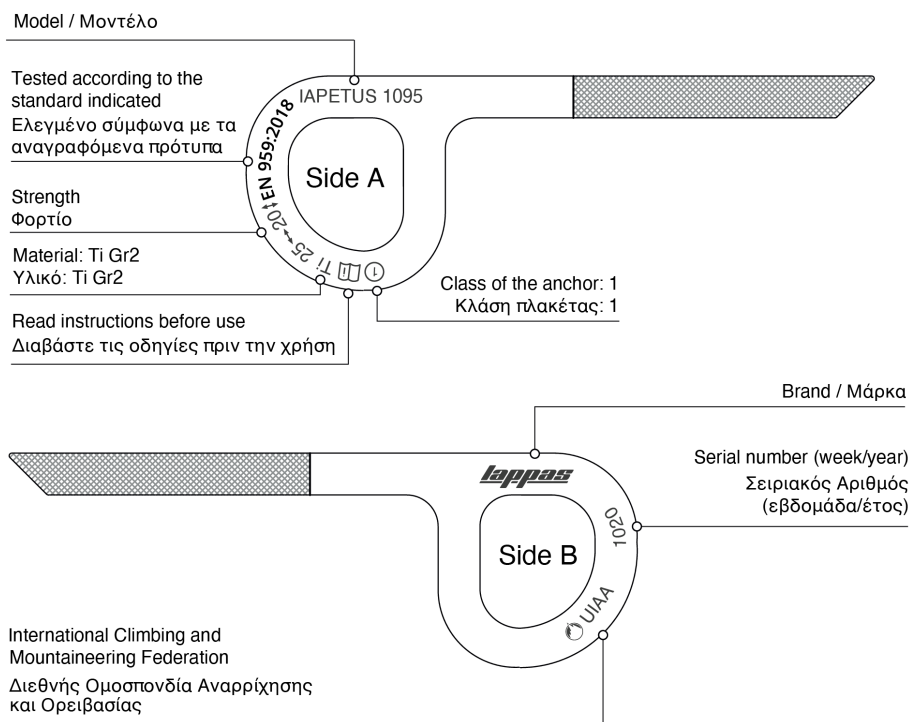

Anchor class, surrounded by a circle:

- Ti : 1

IAPETUS TITAN 10x95mm: Axial Load bearing capacity: 20 kN Radial load bearing capacity: 25 kN  
 IAPETUS TITAN 10x115mm: Axial Load bearing capacity: 20 kN Radial load bearing capacity: 25 kN

See the table below on the “SECURITY REQUIREMENTS”, with the effective resistance.

Markings should always be visible for the lifetime of the product and must not be removed. If the marking of the connector is no longer accessible after installation, it must be provided some additional markings near the device.

### **SECURITY REQUIREMENTS**

Depending on environmental factors, the anchors are potentially responsible for suffering from:

- galvanic corrosion
- corrosion
- SCC: Stress Corrosion Cracking

## Rock Anchors class & characteristics

ANCHOR CLASS	LOCATION	CHARACTERISTICS	POTENTIAL MATERIALS	REMARKS
1	highly aggressive SCC and/or corrosive environment	<b>SCC in evidence:</b> high chloride concentration, sea salt + other salts (from karst: limestone/dolomite) & acidic environment	Titanium grade 2 & some high-end High Corrosion Resistant (HCR) steels	Although SCC is a commonly associated with seaside cliffs, it can also occur in inland locations. The wind can blow salt over 100 km inland, and beyond the reach of sea breezes the rock itself can contain the ions that promote SCC.
2	outdoor environment not aggressive enough to cause SCC	<b>No SCC in evidence and none suspected:</b> some corrosion agents	AISI 316(L) and better	304 steel is not recommended any more for outdoor use!
3	indoor use, climbing gyms	<b>No SCC in evidence and none suspected</b>	no limitation with respect to corrosion	Bolts in indoor gyms in proximity to industrial areas, swimming pools, or the sea may require additional corrosion resistance.

Our anchors IAPETUS TITAN 10x95mm | 10x115mm, made of Titanium Gr 2 and therefore of class 1 are suitable for environments that are aggressive to cause SCC.

We recommend using an epoxy glue that has good durability and resistance (see website [www.lappasclimbing.com](http://www.lappasclimbing.com)).

### **Risks of use and responsibility**

This product should only be used by competent persons who have received the adequate training by an instructor. It's your responsibility to know this product, learn to use it, learn the proper techniques and the safety measures.

You alone are solely fully all risks and responsibilities for any damage, injury or death which may derive to yourself or others persons, following incorrect use of each kind of product of the company LAPPAS S.A.. Keep these instructions that describe the range of use and the methods of application of the product. You are responsible to consider all the notices and updates regarding these products.

No liability will be recognized by the company LAPPAS S.A. for damages, injuries or death caused by: improper use (also due to support or unsuitable environment), stresses the product beyond its limits, modification of the product, repairs made by unauthorized persons.

If you are not able to undertake this responsibility and take these risks, do not use these products. Your life depends on the continual efficiency of your equipment (we strongly recommend that the equipment is for personal use) and its history (use, storage, controls, etc.).

If the product is not for personal use (for example is of associations), we strongly recommend that the pre and post use controls carried out by a competent person. Check and make sure that all the anchors do not show signs of cracks or wear.

Before using the equipment consider as a possible rescue, in case of emergency, it can be performed safely and efficiently.

### **CHECKS AND INSPECTIONS**

#### **Before each use**

Before each use, make sure that the product is:

- in very good condition and works properly
- suitable for the use you intend to do: they are authorized only the techniques not crossed out, any other use is forbidden: beware of death! The examples

shown in the user's manual are just some of the wrong applications: there are many other more that is impossible to list

– free of cracks, deformations and corrosions

Check carefully the state and the type of support in that you want to fix the product. If the rock is cracked, etc., avoid it. If you have the minimum doubt about the safety and the effectiveness of the product, replace it immediately.

### **During each use**

Check regularly the state of the product and make sure you have correctly connected all devices among themselves. Check visually the goodness of the anchor.

The resistance of natural/not natural anchors, in the rock, can't be guaranteed in advance, so it's necessary a critical judgment by the user, to guarantee an appropriate protection.

### **Periodical inspections**

It is not enough to check the material before and during use, but periodic checks must be made by a competent person at least every 2 years for checks on the anchoring system and 4 years for checks on the support structure and anchors. Pre and post use checks must be carried out by a competent person (adapt the frequency according to the intensity and type of use and to the place where the anchor is installed). When the checks are carried out it is necessary to report the results on a check sheet. This must allow you to record a lot of data.

### **WARNING:**

You must make regular periodic inspections! The safety of the users depends on the continued efficiency and durability of the equipment.

We recommend to hold and fill the inspection sheet for each component, system and sub-system.

### **COMPATIBILITY**

This product can be used in combination with personal protective equipment compliant with the relative instructions for use (if there is compatibility of devices there is good functional interaction). An anchor must be compatible to the device to which it is connected. If the connection is incompatible, the safety functions of the system (release or breakage) may be compromised.

Compatible devices are, for example, manufactured and certified harnesses according to EN 12277, dynamic ropes certified according to EN 892, connectors in accordance with 12275, etc..

### **WARNING:**

Please avoid the use of these anchors with others made of different materials. For example, do not use plates made of stainless steel and galvanized steel anchors, because also in a modest hostile environment there will be obtained effects of galvanic corrosion.

Contact LAPPAS S.A. if you are not sure of the compatibility of your device.

### **OPERATING MODE**

Placing anchors using an epoxy glue is a simple but delicate process. If it is not executed correctly, resistance to tensile and shear force can be seriously compromised. The only type of epoxy glue to use is:

- **Hilti HIT RE 500 V4**

**Attention: the use of polyester-based glues is not recommended.**

**The load-bearing of the anchor cannot be guaranteed if the rock in which it is installed is weak or not very homogeneous, not consolidated or with micro-cracks. In these cases, we recommend using the anchor as long as possible.**

## **Instructions are as follows:**

1. Choose an undamaged and solid area of rock away from edges.
2. Strike the surface with a hammer to determine the rock consistency.
3. Drill a hole perpendicular to the placement surface. (Please note: the hole must be 2mm wider than the shank diameter). The depth should be no more than 5mm longer than the anchor shank to reduce epoxy glue waste. To optimize placement, it is (almost) always recommended to also make a groove in line with the desired load. To do this, hold the drill perpendicularly to the surface and make a 10mm-deep hole 52mm from the center axis of the upper hole, in line with the directional force. Now position the drill at a 45° angle and, beginning from the hole just created, make a 6-10mm deep groove to join with the upper hole. Clean well and test by inserting a “IAPETUS TITAN” eyebolt into the hole. The anchor must be positioned correctly inside the groove. When the epoxy glue is applied, this ensures perfect and permanent placement which is unaffected by vibrations and transversal force. Use the drill to make any necessary adjustments.
4. Clean the hole either with an appropriate Blow-out Bulb or by blowing through a rubber tube. A Cleaning brush is also recommended to completely remove any dust from inside the hole.
5. Using an injector gun, inject the correct amount of epoxy glue into the base of the hole and along the groove.
6. Insert the anchor to a point about 1cm from the base and twist in semicircles to coat the surface of the shank completely in epoxy glue. Now insert the “IAPETUS TITAN” fully into the groove. A small amount of epoxy glue may exit from the hole edges and around the eye, demonstrating a good fit. Use latex gloves throughout this procedure. Remove any excess epoxy glue from the edges of the eyelet, sealing the edges. This is important to prevent water from entering in the future. This is particularly important in marine environments.
7. When using this anchor to protect overhangs or roofs, use the same process as above but do not create the groove. Once the anchor is in place, hold it in position using a couple of cocktail sticks (or similar) between the edge of the hole and the shank's surface. Without this the anchor has a tendency to fall out of the vertical hole. Once the epoxy glue has hardened the two sticks can be easily removed.
8. After applying the epoxy glue do not touch the anchor. Leave to set for at least 24 hours – if possible, for 2/3 days, depending on ambient temperature. Respect any advice given by the epoxy glue's manufacturer.
9. The rope can be connected directly to all our IAPETUS TITAN (10x95 | 10x115).

## **Resistance**

Our products comply with the requirements of EN 959:2018 and they also comply with the requirements of UIAA 123\_3.

Please note that the company LAPPAS S.A. disclaims any responsibility in case of improper installation and/or use in inappropriate rocks.

## **Precautions for use**

Attention: after a fall or a major impact, check:

- rock around the anchor: there must be no cracks
- anchor: observe it visually and check that there are no cracks, deformation, and verify that the anchor is not rotated or moved. If you're in doubt replace it. Use only if the external temperature is between -40 ° and + 50 ° C.

## **GENERAL INFORMATION**

### **Life time**

The potential life time of the Lappas products is undefined (it is advisable to replace them anyway after 10 years). It is known that equipment may degrade progressively when it is used, so the actual life time of the products cannot be quantified precisely, but occurs when the product becomes obsolete in the system or when it meets one of elimination.

The lifetime is also reduced considerably by the conditions and intensity of use: heavy use, contact with chemicals substances, use near sea water or splashing water (in this case we recommend the use our "Marine" anchors line, which are much more resistant to corrosion of salt), high temperatures, abrasions or cuts, damage to parts/components of the product, chemical environments, mud, sand, snow, ice, competence of the user, violent shocks, storage, are some of the factors that accelerating product wear.

### **WARNING:**

The duration may be limited to only one use in specific conditions (contact with acids, dangerous chemicals products, if the product suffers sharp falls or tensions, etc., this list is endless). If it's installed in a marine environment or other potentially corrosive environments, it would be better to use materials with high corrosion resistance. Despite this, we invite the installer to monitor and inspect the anchors at regular intervals to check their statue.

### **ATTENTION:**

Anchors installed in marine areas, on rocks containing ferrous inclusions or other minerals of not certain nature, in some cases may suffer violent corrosive attacks that can compromise its use even in very short time!

Attention: The life of the anchorage is limited in the case of an environmental stress corrosion cracking SCC.

The installer can break or cut off the product when it becomes obsolete in the system or when it meets one of the eliminations.

### **Elimination**

Do not use the product:

- after a violent fall, since no visible deformations could be considerably impaired resistance
- if the result of the check is not satisfactory
- when you do not know the entire history of its use and when it becomes obsolete and you have the slightest doubt about its reliability
- general wear of the plate and / or significant reduction of the section in correspondence with the carabiner
- if there're cracks, wear or defects
- when corrosion severely alters the surface condition.

Destroy retired equipment to prevent further use.

### **Product obsolescence**

The product may be judged obsolete and thus retired from service, when they occur, for example, incompatibility with other equipment, changes in applicable standards, etc.

### **Chemical products**

All chemicals, solvents or corrosive substances can be very dangerous for these items. If there's a chance to come in contact with these substances contact directly LAPPAS S.A. indicating composition and exact name of the product, so we can respond properly after studying the case.



### **Changes and repairs**

Modifications and/or repairs not authorized by the company LAPPAS S.A. are prohibited because they can reduce product performance. Repairs or modifications must be carried out inside the department production of LAPPAS S.A. and not outside.

### **Warranty**

This product has a 3-year warranty, against every defect in manufacturing or material. The guarantee excludes oxidation, normal wear and tear, modifications or alterations, incorrect storage, damage due to accidents, negligence and improper use.

### **Transport**

It does not need any special precautions for transportation, however avoid contact with chemical reagents or other corrosive substances.

### **Maintenance and storage**

The user should not perform any special maintenance, but should be limited to the cleaning of the product as explained below.

**Cleaning:** rinse frequently the product only with lukewarm fresh water (max 40°C). Leave it to dry naturally away from direct heat. Do not put the product in contact with corrosive substances or solvents. Do not store at extreme temperatures.

**Storage:** after cleaning and drying, store the equipment in a dry, cool, dark place (avoid UV rays), chemically neutral place (absolutely avoid saline environments), away from sharp edges, heat, humidity, corrosive substances or other potentially harmful conditions.

**Caution:** Do not store when wet! Improper storage, as well as the aging of the product, may damage it and impair its performance and safety.

### **Testing and conformity**

This product is tested in accordance with the standard EN 959:2018 by the accredited testing laboratory and certified by accredited certification body of VVUÚ, a.s., Pikartská 1337/7, 716 00 Ostrava – Radvanice, Czechia. This product is also tested and complies UIAA 123: Quality Label of the International Climbing and Mountaineering Federation.

**Attention:** laboratory tests, the instructions for use and standards are not always able to reproduce the practice, so the results obtained in real conditions of use in natural environments may sometimes differ to a considerable degree. The best instructions can be had from continuous use under the supervision of qualified and prepared instructors.